

SD card real time data Recorder, USB/RS232

SOUND LEVEL METER

Model : SL-4023SD



Your purchase of this SOUND LEVEL METER with SD CARD DATA RECORDER marks a step forward for you into the field of precision measurement. Although this METER is a complex and delicate instrument, its durable structure will allow many years of use if proper operating techniques are developed. Please read the following instructions carefully and always keep this manual within easy reach.



OPERATION MANUAL

TABLE OF CONTENTS

1. FEATURES.....	1
2. SPECIFICATIONS.....	2
3. FRONT PANEL DESCRIPTION.....	6
3-1 Display.....	6
3-2 Power Button (ESC, Backlight Button).....	6
3-3 Hold Button (Next Button).....	6
3-4 REC Button (Enter Button).....	6
3-5 Range Button (▲ Button, Time Check Button).....	6
3-6 A/C Button (▼ Button, Sampling check Button).....	6
3-7 Fast/Slow Button (SET Button).....	6
3-8 Peak Hold Button (Logger Button).....	6
3-9 Microphone.....	6
3-10 AC output terminal.....	6
3-11 Calibration VR.....	6
3-12 RS-232 output terminal.....	6
3-13 DC 9V adapter socket.....	6
3-14 Tripod Fix Nut.....	6
3-15 Battery Cover Screws.....	6
3-16 Stand.....	6
3-17 Battery compartment/Cover.....	6
3-18 SD card socket.....	6
4. MEASURING PROCEDURE.....	7
5. DATALOGGER.....	9
5-1 Preparation before execute datalogger function.....	9
5-2 Auto Datalogger (Set sampling time ≥ 1 second).....	10
5-3 Manual Datalogger (Set sampling time = 0 second).....	11
5-4 Check time information.....	12
5-5 Check sampling time information.....	12
5-6 SD Card Data structure.....	12
6. Saving data from the SD card to the computer.....	14
7. ADVANCED SETTING.....	15
7-1 Set clock time (Year/Month/Date, Hour/Minute/ Second).....	16
7-2 Decimal point of SD card setting.....	17
7-3 Auto power OFF management	17
7-4 Set beeper Sound ON/OFF.....	18
7-5 Set sampling time	18
7-6 SD memory card format.....	19
8. POWER SUPPLY from DC ADAPTER.....	19
9. BATTERY REPLACEMENT.....	19
10. RS232 PC serial interface.....	20
11 CALIBRATION	21
12. FREQUENCY WEIGHTING CHARACTERISTICS OF A & C NETWORKS.....	22
13. TIME WEIGHTING (FAST & SLOW) CHARACTERISTICS.....	22
14. PATENT.....	23

1. FEATURES

- * Main functions are designed to meet IEC 61672 class 2.
- * A & C weighting networks comply with standards.
- * 0.5" standard microphone head.
- * Time weighting (Fast & Slow) dynamic characteristic modes.
- * Build External calibration VR.
- * Auto range & Manual range selection.
- * Available for external calibration adjustment.
- * Condenser microphone for high accuracy & long-term stability.
- * Memory function to store the Max. & Min. value.
- * Hold and Peak Hold functions.
- * Real time SD memory card Datalogger, it Built-in Clock and Calendar, real time data recorder, sampling time set from 1 second to 3600 seconds.
- * Manual datalogger is available (set the sampling time to 0 second), during execute the manual datalogger function, it can set the different position (location) No. (position 1 to position 99).
- * Innovation and easy operation, computer is not need to setup extra software, after execute datalogger, just take away the SD card from the meter and plug in the SD card into the computer, it can download the all the measured value with the time information (year/month/date/ hour/minute/second) to the Excel directly, then user can make the further data or graphic analysis by themselves.
- * SD card capacity : 1 GB to 16 GB.
- * LCD with green light backlight, easy reading.
- * Can default auto power off or manual power off.
- * Data hold, record max. and min. reading.
- * Microcomputer circuit, high accuracy.
- * Power by UM3/AA (1.5 V) x 6 batteries or DC 9V adapter.
- * RS232/USB PC COMPUTER interface.
- * Heavy duty & compact housing case.

2. SPECIFICATIONS

Circuit	Custom one-chip of microprocessor LSI circuit.
Display	LCD size : 52 mm x 38 mm LCD with green backlight (ON/OFF).
Measurement Range	30 - 130 dB.
Resolution	0.1 dB.
Function	dB (A & C frequency weighting), Time weighting (Fast, Slow), Peak hold, Data hold Record (Max., Min.).
Accuracy (23 ± 5 °C)	<p>Characteristics of " A " frequency weighting network meet IEC 61672 class 2.</p> <p>Under 94 dB input signal, the accuracy are :</p> <p>31.5 Hz ± 3.5 dB 63 Hz ± 2.5 dB 125 Hz ± 2.0 dB 250 Hz ± 1.9 dB 500 Hz ± 1.9 dB 1 K Hz ± 1.4 dB 2 K Hz ± 2.6 dB 4 K Hz ± 3.6 dB 8 K Hz ± 5.6 dB</p> <p><i>Remark :</i> <i>The above spec. are tested under the environment RF Field Strength less than 3 V/M & frequency less than 30 MHz only.</i></p>

Frequency Weighting Network	<p>Characteristics of A & C.</p> <p>A weighting : The characteristic is simulated as "Human Ear Listing" response. Typical, if making the environmental sound level measurement, always select to A weighting.</p> <p>C weighting The characteristic is near the "FLAT" response. Typical, it is suitable for checking the noise of machinery (Q.C. check) & knowing the sound pressure level of the tested equipment.</p>
Time weighting (Fast & Slow)	<p>Fast - $t = 200$ ms * "Fast" range is simulated the human ear response time weighting.</p> <p>Slow - $t = 500$ ms * "Slow" range is easy to get the average values of vibration sound level.</p>
Data hold	To freeze the measurement value.
Peak hold	To keep the peak (max.) measurement value.
Range selector	<p><i>Auto range</i> : 30 to 130 dB.</p> <p><i>Manual range</i> : 3 range, 30 to 80 dB, 50 to 100 dB, 80 to 130 dB, 50 dB on each step, with over & under range indicating.</p>
Frequency	31.5 to 8,000 Hz.
Microphone type	Electric condenser microphone.
Microphone size	Out size, 12.7 mm DIA. (1/2 inch).

Calibration VR	Build in external calibration VR, easy to calibrate on 94 dB level by screw driver. * Calibrated via external SOUND CALIBRATOR (SC-941, optional).	
Calibrator	B & K (Bruel & kjaer), MULTIFUNCTION ACOUSTIC CALIBRATOR 4226.	
Datalogger Sampling Time Setting range	Auto	1 second to 3600 seconds <i>@ Sampling time can set to 1 second, but memory data may loss.</i>
	Manual	Push the data logger button once will save data one time. <i>@ Set the sampling time to 0 second.</i> <i>@ Manual mode, can also select the 1 to 99 position (Location) no.</i>
Memory Card	SD memory card. 1 GB to 16 GB.	
Advanced setting	<ul style="list-style-type: none"> * Set clock time (Year/Month/Date, Hour/Minute/ Second) * Decimal point of SD card setting * Auto power OFF management * Set beep Sound ON/OFF * Set sampling time * SD memory card Format 	
Over Indication	Show " - - - - ".	
Data Hold	Freeze the display reading.	
Memory Recall	Maximum & Minimum value.	
Sampling Time of Display	Approx. 1 second.	
Data Output	RS 232/USB PC computer interface. <ul style="list-style-type: none"> * <i>Connect the optional RS232 cable UPCB-02 will get the RS232 plug.</i> * <i>Connect the optional USB cable USB-01 will get the USB plug.</i> 	
AC output	AC 0.5 Vrms corresponding to each range step. <ul style="list-style-type: none"> * <i>Output impedance : 600 ohm.</i> 	

Power off	Auto shut off saves battery life or manual off by push button.
Operating Temperature	0 to 50 °C .
Operating Humidity	Less than 85% R.H.
Power Supply	* Alkaline or heavy duty DC 1.5 V battery (UM3, AA) x 6 PCs, or equivalent.
	* DC 9V adapter input. (AC/DC power adapter is optional).
Power Current	Normal operation (w/o SD card save data and LCD Backlight is OFF) : <i>Approx. DC 12 mA.</i>
	When SD card save the data but and LCD Backlight is OFF) : <i>Approx. DC 51 mA.</i>
	* <i>If LCD backlight on, the power consumption will increase approx. 30 mA.</i>
Weight	489 g/1.08 LB.
Dimension	245 x 68 x 45 mm. (9.6 x 2.7x 1.9 inch).
Accessories Included	* Instruction manual.....1 PC
Optional Accessories	* Sound calibrator (94 dB), SC-941. * Sound calibrator (94/114 dB), SC-942. * Sound wind shield ball, SB-01 * SD Card (2 GB) * USB cable, USB-01. * RS232 cable, UPCB-02. * Data Acquisition software, SW-U801-WIN. * AC to DC 9V adapter. * Soft carrying case, CA-05A. * Hard carrying case, CA-06.

3. FRONT PANEL DESCRIPTION

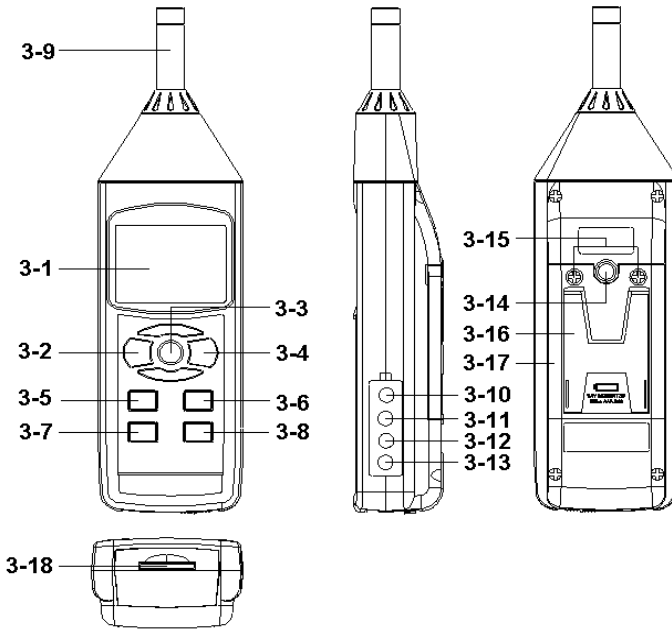

Fig. 1

- 3-1 Display.
- 3-2 Power Button (ESC, Backlight Button)
- 3-3 Hold Button (Next Button)
- 3-4 REC Button (Enter Button)
- 3-5 Range Button (▲ Button, Time Check Button)
- 3-6 A/C Button (▼ Button, Sampling check Button)
- 3-7 Fast/Slow Button (SET Button)
- 3-8 Peak Hold Button (Logger Button)
- 3-9 Microphone
- 3-10 AC output terminal
- 3-11 Calibration VR
- 3-12 RS-232 output terminal.
- 3-13 DC 9V adapter socket.
- 3-14 Tripod Fix Nut
- 3-15 Battery Cover Screws
- 3-16 Stand
- 3-17 Battery compartment/Cover
- 3-18 SD card socket

4. MEASURING PROCEDURE

4-1 Sound level meter

- 1) Power on by pressing the " Power On/Off Button " (3-2, Fig. 1) , the meter's default function is " Auto range " , " A frequency weighting " & " Fast time weighting ". The LCD display will show the unit " A. Fast Auto " .
- 2) Select " A " or " C " frequency weighting by pressing the " A/C Button " (3-6, Fig. 1) .

Note :

a. The characteristic table of A, C weighting, please ref. page 22.

b. The characteristic of A weighting is simulated as the " Human Ear Listening " response.

Typically always select the A weighting when makes environmental sound level measurement.

c. The C weighting characteristic is near the " FLAT " response. Typically it is suitable for checking the noise of machinery (Q.C. check) & knowing the real sound level of the tested equipment.

- 3) Determine proper measuring range by pressing the " Range Button " (3-5, Fig. 1) .
After power on the default range is " Auto range " .
In the same time the lower right display will show the text of " Auto " .
Under the auto range, press the " Range Button " (3-5, Fig. 1) once step by step will enter to the manual range (range 1, range 2, range 3) and auto range in sequence. There are still 3 manual ranges for your choice :

- * *Manual range 1 , 30 - 80 dB range :*
Display will show the unit of " 30 - 80 ".
- * *Manual range 2 , 50 - 100 dB range :*
Display will show the unit of " 50 - 100 ".
- * *Manual range 3 , 80 - 130 dB range :*
Display will show the unit of " 80 - 130 ".

4) According to various measuring sound source, select the Time Weighting (Fast or Slow) by pressing the " Time Weighting Button " (3-7, Fig. 1).

Note :

- a. If select the function of " Fast " time weighting, the display will show the unit of " FAST".*
- b. If select the function of " Slow " time weighting, the display will show the unit of " SLOW ".*

4-2 Data Hold

During the measurement, press the " Hold Button " (3-3, Fig. 1) once will hold the measured value & the LCD will display a " HOLD " symbol.

Press the " Hold Button " once again will release the data hold function.

4-3 Data Record (Max., Min. reading)

- 1) The data record function records the maximum and minimum readings. Press the " REC Button " (3-4, Fig. 1) once to start the Data Record function and there will be a " REC " symbol on the display.
- 2) With the " REC " symbol on the display :
 - a) Press the " REC Button " (3-4, Fig. 1) once, the " REC MAX " symbol along with the maximum value will appear on the display.
If intend to delete the maximum value, just press the " Hold Button " (3-3, Fig. 1) once, the display will show the " REC " symbol only & execute the memory function continuously.

- b) Press the " REC Button " (3-4, Fig. 1) again, the " REC MIN " symbol along with the minimum value will appear on the display.
If intend to delete the minimum value, just press the " Hold Button " (3-3, Fig. 1) once, the display will show the " REC " symbol only & execute the memory function continuously.
- c) To exit the memory record function, just press the " REC " button > 2 seconds at least. The display will revert to the current reading.

4-4 LCD Backlight ON/OFF

After power ON, the " LCD Backlight " will light automatically. During the measurement, press the " Backlight Button " (3-2, Fig. 1) once will turn OFF the " LCD Backlight " .

Press the " Backlight Button " once again will turn ON the " LCD Backlight " again.

5. DATALOGGER

5-1 Preparation before execute datalogger function

- a. Insert the SD card
Prepare a " SD memory card " (1 GB to 16 GB, optional), insert the SD card into the " SD card socket " (3-18, Fig. 1). The front panel of the SD card should face against the the down case.
- b. SD card Format
If SD card just the first time use into the meter, it recommend to make the " SD card Format " at first. , please refer chapter 7-6 (page 19).

c. Time setting

If the meter is used at first time, it should to adjust the clock time exactly, please refer chapter 7-1 (page 16).

d. Decimal format setting



The numerical data structure of SD card is default used the " ." as the decimal, for example "20.6" "1000.53" . But in certain countries (Europe ...) is used the " , " as the decimal point, for example " 20, 6 " "1000,53". Under such situation, it should change the Decimal character at first, details of setting the Decimal point, refer to Chapter 7-2, page 17.

5-2 Auto Datalogger (Set sampling time \geq 1 second)

a. Start the datalogger

Press the " REC Button (3-4, Fig. 1) once , the LCD will show the text " REC ", then press the " Logger Button " (3-8, Fig. 1), the " REC " will flashing, at the same time the measuring data along the time information will be saved into the memory circuit.

The Display will show also show text " LOGGER " when the data save into the memory circuit.

Remark :

How to set the sampling time, refer to Chapter 7-5, page 18.

b. Pause the datalogger

During execute the Datalogger function , if press the " Logger Button " (3-8, Fig. 1) once will pause the Datalogger function (stop to save the measuring data into the memory circuit temporally). In the same time the text of " REC " will stop flashing.

Remark :

If press the " Logger Button " (3-8, Fig. 1) once again will execute the Datalogger again, the text of " REC " will flashing .

c. Finish the Datalogger

During pause the Datalogger, press the " REC Button " (3-4, Fig. 1) continuously at least two seconds, the " REC " indicator will be disappeared and finish the Datalogger.

Remark :

When the battery is under the low battery condition (show the low battery indicator), the Datalogger function is disable.

5-3 Manual Datalogger (Set sampling time = 0 second)

a. Set sampling time is to 0 second

Press the " REC Button (3-4, Fig. 1) once , the LCD will show the text " REC ", then press the " Logger Button " (3-8, Fig. 1) once, the " REC " will flashing once , at the same time the measuring data along the time information and the Position no. will be saved into the memory circuit.

Remark :

- * Lower Display will show the Position/Location no. (P1, P2... P99) .*
- * During execute the Manual Datalogger, press the " SET Button " (3-7, Fig. 1) once, then use the " ▲ Button " (3-5, Fig. 1) or " ▼ Button " (3-6, Fig. 1) to set the measuring position (1 to 99, for example room 1 to room 99) to identify the measurement location. After finish the adjustment location no., press the " Enter Button " to entry.*

b. Finish the Datalogger

Press the " REC Button " (3-4, Fig. 1) continuously at least two seconds, the " REC " indication will be disappeared and finish the Datalogger.

5-4 Check time information

During the measurement if press " Time check Button " (3-5, Fig. 1) > 2 seconds, the lower LCD display will present the time information of Year/Month, Date/Hour, Minute/Second.

5-5 Check sampling time information

During the measurement , If press " Sampling Check Button " (3-6, Fig. 1) > 2 seconds, the lower LCD display will present the Sampling time information in second unit.

5-6 SD Card Data structure

- 1) When the SD card is used into the meter, the SD card
When the first time, the SD card is used into the meter, the SD card will generate a folder :

SLA01

- 2) If the first time to execute the Datalogger, under the route SLA01\, will generate a new file name SLA01001.XLS.
After exist the Datalogger, then execute again, the data will save to the SLA01001.XLS until Data column reach to 30,000 columns, then will generate a new file, for example SLA01002.XLS
- 3) Under the folder SLA01\, if the total files more than 99 files, will generate anew route, such as SLA02\

4) The file's route structure :

```

SLA01\
  SLA01001.XLS
  SLA01002.XLS
  .....
  SLA01099.XLS
SLA02\
  SLA02001.XLS
  SLA02002.XLS
  .....
  SLA02099.XLS
SLXXX\

```

Remark : XX : Max. value is 10.

6. Saving data from the SD card to the computer (EXCEL software)

- 1) After execute the Data Logger function, take away the SD card out from the " SD card socket " (3-18, Fig. 1).
- 2) Plug in the SD card into the Computer's SD card slot (if your computer build in this installation) or insert the SD card into the " SD card adapter ". then connect the " SD card adapter " into the computer.
- 3) Power ON the computer and run the " EXCEL software ". Down load the saving data file (for example the file name : SLA01001.XLS, SLA01002.XLS) from the SD card to the computer. The saving data will present into the EXCEL software screen (for example as following EXCEL data screens) , then user can use those EXCEL data to make the further Data or Graphic analysis usefully.

EXCEL data screen (for example)

A1		Place			
	A	B	C	D	E
1	Place	Date	Time	Value	Unit
2	1	2009/10/16	16:47:05	60.8	dB
3	2	2009/10/16	16:47:07	66.9	dB
4	3	2009/10/16	16:47:09	68.8	dB
5	4	2009/10/16	16:47:11	71	dB
6	5	2009/10/16	16:47:13	82.3	dB
7	6	2009/10/16	16:47:15	92.3	dB
8	7	2009/10/16	16:47:17	93.1	dB
9	8	2009/10/16	16:47:19	93.1	dB
10	9	2009/10/16	16:47:21	89.8	dB
11	10	2009/10/16	16:47:23	90.2	dB
12	11	2009/10/16	16:47:25	89.9	dB
13	12	2009/10/16	16:47:27	93.2	dB
14	13	2009/10/16	16:47:29	90.7	dB
15	14	2009/10/16	16:47:31	82	dB
16	15	2009/10/16	16:47:33	86.2	dB

EXCEL graphic screen (for example)



7. ADVANCED SETTING

Under do not execute the Datalogger function, press the " SET Button " (3-7, Fig. 1) continuously at least two seconds will enter the " Advanced Setting " mode. then press the " Next Button " (3-3, Fig. 1) once a while in sequence to select the six main function, the lower display will show :

dAtE.....Set clock time (Year/Month/Date, Hour/Minute/Second)

dEC.....Set SD card Decimal character

PoFF..... Auto power OFF management

bEEP.....Set beeper sound ON/OFF

SP-t..... Set sampling time

Sd-F..... SD memory card Format

Remark :

During execute the " Advanced Setting " function, if press " ESC Button " (3-2, Fig. 1) once will exit the " Advanced Setting " function, the LCD will return to normal screen.

7-1 Set clock time (Year/Month/Date, Hour/Minute/ Second)

When the lower display show " dAtE "

- 1) Press the " Enter Button " (3-4, Fig. 1) once, Use the " ▲ Button " (3-5, Fig. 1) or " ▼ Button " (3-6, Fig. 1) to adjust the value (Setting start from Year value). After the desired value is set, press the " Enter Button " (3-4, Fig. 1) once will going to next value adjustment (for example, first setting value is Year then next to adjust Month, Date, Hour, Minute, Second value).
- 2) After set all the time value (Year, Month, Date, Hour, Minute, Second), the screen will jump to " SD card Decimal character " setting screen (Chapter 7-2).

Remark :

After the time value is setting, the internal clock will run precisely even Power is off (The battery is under normal condition, no low battery condition).

7-2 Decimal point of SD card setting

The numerical data structure of SD card is default used the " ." as the decimal, for example "20.6" "1000.53" . But in certain countries (Europe ...) is used the " ," as the decimal point, for example " 20,6 " "1000,53". Under such situation, it should change the Decimal character at first.

When the lower display show " dEC "

- 1) Use the " ▲ Button " (3-5, Fig. 1) or " ▼ Button " (3-6, Fig. 1) to select the upper value to " bASIC " or " Euro ".

bASIC - Use " ." as the Decimal point with default.
Euro - Use " ," as the Decimal point with default.

- 2) After select the upper text to " bASIC " or " Euro ", press the " Enter Button " (3-4, Fig. 1) will save the setting function with default.

7-3 Auto power OFF management

When the lower display show " PoFF "

- 1) Use the " ▲ Button " (3-5, Fig. 1) or " ▼ Button " (3-6, Fig. 1) to select the upper value to " yES " or " no ".

yES - Auto Power Off management will enable.
no - Auto Power Off management will disable.

- 2) After select the upper text to " yES " or " no ", press the " Enter Button " (3-4, Fig. 1) will save the setting function with default.

7-4 Set beeper sound ON/OFF

When the lower display show " bEEP "

- 1) Use the " ▲ Button " (3-5, Fig. 1) or " ▼ Button " (3-6, Fig. 1) to select the upper value to " yES " or " no ".

yES - Meter's beep sound will be ON with default.
no - Meter's beep sound will be OFF with default.

- 2) After select the upper text to " yES " or " no ", press the " Enter Button " (3-4, Fig. 1) will save the setting function with default.

Remark :

After execute the datalogger function, the buzzer sound will off automatically to prevent any interference of the measurement.

7-5 Set sampling time (seconds)

When the lower display show " SP-t "

- 1) Use the " ▲ Button " (3-5, Fig. 1) or " ▼ Button " (3-6, Fig. 1) to adjust the value (0, 1, 2, 5, 10, 30,60, 120, 300, 600, 1800,3600 seconds).

Remark :

If select the sampling time to " 0 second ", it is ready for manual Datalogger.

- 2) After the Sampling value is selected, press the " Enter Button " (3-4, Fig. 1) will save the setting function with default.

7-6 SD memory card Format

When the lower display show " Sd F "

- 1) Use the " ▲ Button " (3-5, Fig. 1) or " ▼ Button " (3-6, Fig. 1) to select the upper value to " yES " or " no ".

yES - Intend to format the SD memory card
no - Not execute the SD memory card format

- 2) If select the upper to " yES ", press the " Enter Button " (3-4, Fig. 1) once again, the Display will show text " yES Ent " to confirm again, if make sure to do the SD memory card format, then press " Enter Button " once will format the SD memory clear all the existing data that already saving into the SD card.

8. POWER SUPPLY from DC ADAPTER

The meter also can supply the power supply from the DC 9V Power Adapter (optional). Insert the plug of Power Adapter into " DC 9V Power Adapter Input Socket " (3-13, Fig. 1). The meter will permanent power ON when use the DC ADAPTER power supply (The power Button function is disable).

9. BATTERY REPLACEMENT

- 1) When the left corner of LCD display show " , it is necessary to replace the battery. However, in-spec. measurement may still be made for several hours after low battery indicator appears before the instrument become inaccurate.

- 2) Loose the " Battery Cover Screws " (3-15, Fig. 1)
and take away the " Battery Cover " (3-17, Fig. 1)
from the instrument and remove the battery.
- 3) Replace with DC 1.5 V battery (UM3, AA,
Alkaline/heavy duty) x 6 PCs, and reinstate the cover.
- 4) Make sure the battery cover is secured after changing
the battery.

10. RS232 PC SERIAL INTERFACE

The instrument has RS232 PC serial interface via a 3.5 mm terminal (3-12, Fig. 1).

The data output is a 16 digit stream which can be utilized for user's specific application.

A RS232 lead with the following connection will be required to link the instrument with the PC serial port.

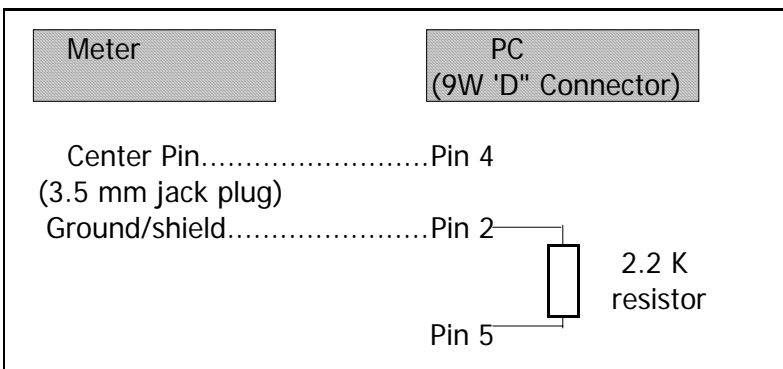

The 16 digits data stream will be displayed in the following format :

D15 D14 D13 D12 D11 D10 D9 D8 D7 D6 D5 D4 D3 D2 D1 D0

Each digit indicates the following status :

D15	Start Word
D14	4
D13	When send the upper display data = 1 When send the lower display data = 2
D12, D11	Annunciator for Display dB = 17
D10	Polarity 0 = Positive 1 = Negative
D9	Decimal Point(DP), position from right to the left 0 = No DP, 1= 1 DP, 2 = 2 DP, 3 = 3 DP
D8 to D1	Display reading, D1 = LSD, D8 = MSD For example : If the display reading is 1234, then D8 to D1 is : 00001234
D0	End Word

RS232 FORMAT : 9600, N, 8, 1

Baud rate	9600
Parity	No parity
Data bit no.	8 Data bits
Stop bit	1 Stop bit

11. CALIBRATION

- 1) Prepare the optional " SOUND CALIBRATOR ", such as " SC-941 " or " SC-942 " (set range to 94.0 dB). Power on the Sound Calibrator & plug calibrator output socket into the " Microphone " head (3-9, Fig. 1) of the Sound Level meter.
- 2) Select manual range to " 50 - 100 dB ".
- 3) Select " Time Weighting " at " Fast " position.

- 4) Select " A " weighting.
- 5) Adjust the " Calibration VR " (3-11, Fig. 1) carefully with a " - " screw driver until the display reading value within " 94 +/- 0.2 " dB.

12. FREQUENCY WEIGHTING CHARACTERISTICS OF A & C NETWORKS

Frequency Hz	A Weighting Charac.	C Weighting Charac.	Tolerance (IEC 61672 class 2)
31.5	-39.4 dB	-3 dB	± 3.5 dB
63	-26.2 dB	-0.8 dB	± 2.5 dB
125	-16.1 dB	-0.2 dB	± 2.0 dB
250	-8.6 dB	0 dB	± 1.9 dB
500	-3.2 dB	0 dB	± 1.9 dB
1 K	0 dB	0 dB	± 1.4 dB
2 K	+1.2 dB	-0.2 dB	± 2.6 dB
4 K	+1 dB	-0.8 dB	± 3.6 dB
8 K	-1.1 dB	-3 dB	± 5.6 dB

13. TIME WEIGHTING (FAST & SLOW) CHARACTERISTICS

Time Weighting Charac.	Max. response ref. continuous signal	Tolerance (IEC 61672 class 2)
F (Fast)	- 1.0 dB	+ 1 dB - 2 dB
S (Slow)	- 4.1 dB	± 2 dB

14. PATENT

The meter (SD card structure) already get patent or patent pending in following countries :

Germany	Nr. 20 2008 016 337.4
JAPAN	3151214
TAIWAN	M 358970
	M 359043
CHINA	ZL 2008 2 0189918.5
	ZL 2008 2 0189917.0
USA	Patent pending